





CONECARTS SMALL CNC1#A0A00W01R2001

CONECARTS LARGE CNC1#B0A00W01R2001

STEP 1

Fasten each single wheel with 4 screws (M8x12) and relative flanged nuts (M8)
The setup of the wheels must be as follows:
- two fixed wheels on side A
- one swivel wheel and one swivel wheel with brake on side B

	M8x12 N°16		M8 N°16		13		5
---	---------------	---	------------	---	----	---	---

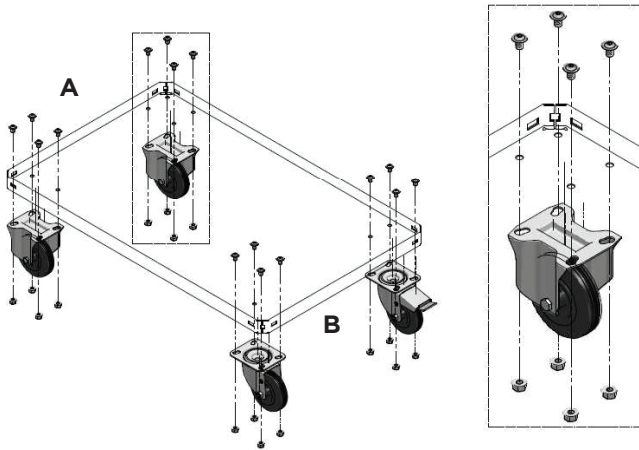

STEP 2



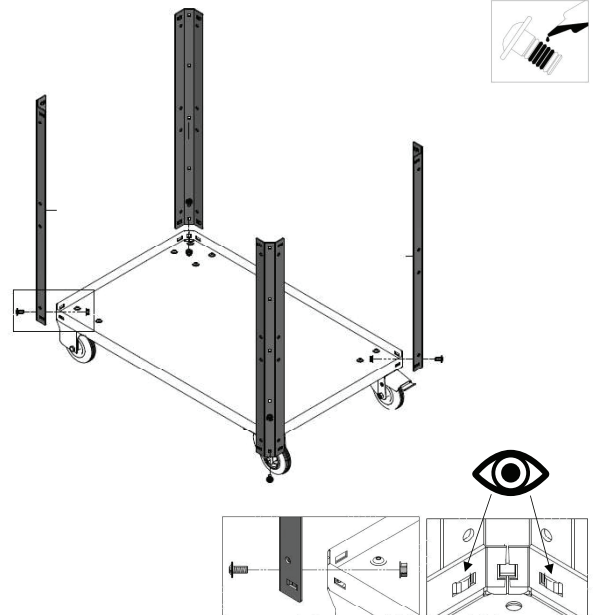

Fasten each single upright to the lower level with 4 screws (M8x16) and relative flanged nuts (M8)

	M8x16 N°04		M8 N°04		13		5
---	---------------	--	------------	---	----	---	---



STEP 3

Fasten the upper surface and each handle at the same time to the correspondent uprights with 4 screws (M8x16) and relative flanged nuts (M8)



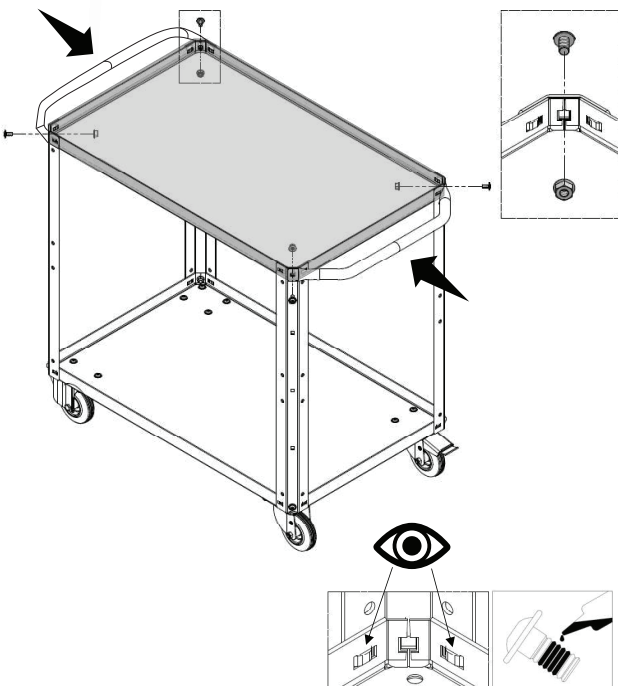

	M8x16 N°04		M8 N°04		13		5
---	---------------	---	------------	---	----	---	---



YOUR CART IS READY!

STEP 4 (OPTIONAL)

Fasten the intermediate shelf to each single upright with 4 screws (M8X16) and relative flanged nuts (M8)

	M8x16 N°04		M8 N°04		13		5
---	---------------	---	------------	---	----	---	---

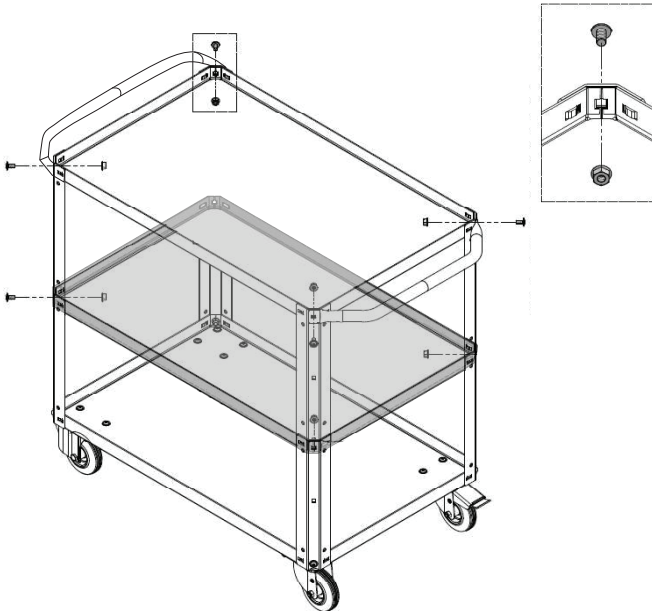
YOUR CART IS READY!
WORKSTATION VERSION

Overturn the upper shelf to transform your cart into a Workstation.

